

## Comparing Stereo Arrays: An Users' Guide to the Session Materials

### *Introduction*

From its introduction as a novelty in 1881 to the present day, stereophonic audio has relied on arrays of microphones to capture and then reproduce (or simulate) the original audio wavefront. In Greek, “stereos” means “solid” and refers to spatial dimensions of depth, breadth, and height; thus stereo reproduction is intended, at least theoretically, to present a natural version of sound heard from multiple directions. While multichannel audio may also be considered “stereo,” most often this term refers to two-channel reproduction.

In *The Microphone Book*, John Eargle noted that stereo recording:

...makes use of many diverse microphone arrays and techniques. At the basis of them are a set of fundamental two- or three-microphone arrays for picking up a stereo sound stage for reproduction over a pair of loudspeakers. In stereo reproduction, the listener is able to perceive images on the stereo sound stage which may span the entire angular width of the loudspeaker array. The sound sources that appear between the loudspeakers are known as “phantom images” because they appear at positions where there are no physical...sources of sound (2004, p. 166).

At minimum, stereo reproduction requires two transmission channels played back over two loudspeakers. Based in part on the research of Alan Blumlein at EMI and Dr. Harvey Fletcher at Bell Telephone Laboratories in the early 1930's, recording engineers have employed two-microphone stereo arrays in an attempt to “convey to the listener a true directional impression...” (Blumlein, p. 93). In broad terms, the most common arrays are distinguished by the inter-microphone spacing. These categories are: coincident pairs, including middle-side and Blumlein techniques; near-coincident pairs, such as the ORTF and NOS arrays; spaced pairs, sometimes referred to as AB stereo; and binaural systems, including dummy heads, spheres, and baffled stereo arrays. While there are multiple variations of each, these techniques have been used for more than 70 years, and recent improvements in high definition digital recording have inspired

engineers and producers to re-examine the value of simple arrays (*Mix Online*, 2000; LeGrou, 2005).

Surprisingly, while there is an immense collection of written material about stereo microphone techniques, previously there were no recordings of multiple concurrent arrays available for critical listening or individual study. For this reason, I created this series of audiophile stereo recordings, available online along with more sessions, expanded data file types, and additional documentation at [www.stereoarray.com](http://www.stereoarray.com). As an online resource, it can be revised and expanded over time.

### *Stereo Arrays*

Different stereo arrays reproduce the original sound field in markedly different ways: variations between the source placement and the apparent placement in loudspeakers are referred to as angular (or geometric) distortions. Typically, audio sources, such as an orchestra, occupy a sector greater than 60 degrees, so angular compression is required to make the source “fit” within the reproduced sound stage; similarly, a narrow sound source may be widened through angular expansion. When choosing an array, the recording engineer must first determine the “sector of the original sound field in front of the microphone system which will be perceived as a virtual sound image between the loudspeakers,” referred to as the stereophonic recording angle (Williams, 2004, p. 14). Based on the placement (both in relation to each other as well as within the space) and polar patterns of the microphones used, each stereo array technique is capable of capturing different SRA’s with varying degrees of angular distortion; for example, first-order coincident cardioid microphones arranged at a 90 degree angle (XY pair) have a SRA of  $\pm 90$  degrees (180 degrees in total) with an angular distortion of roughly 6 degrees, narrowing the source in the soundstage (Williams, 2004). Sonically, angular distortion results in reproduced elements either “clumping” in the center of the sound stage, producing a narrow stereo image, or extending out towards the far left and right channels, producing a “hole in the middle” effect (Figure 1).

Intended to capture both the direct and reflected sound accurately, **binaural** recordings (Fig. 2) produce a remarkably accurate stage width and spatial effect when

monitored over headphones: each channel is transmitted to its corresponding earphone with no crosstalk. However, the playback of binaural recordings over loudspeakers allows unwanted audio from the left channel to interfere with the right and vice versa, resulting in poor imaging from comb filtering effects.

In contrast to binaural recording techniques, coincident stereo arrays include a pair of directional microphones with their capsules positioned as close together as possible, such that “they respond only to amplitude cues in the program pickup, since their proximity precludes any time related cues” (Eargle, 2004, p. 168). Referred to as an **XY pair** (Fig. 3), coincident cardioid microphones with an included angle of 90 degrees typically produce an excellent image focus and mono-compatibility but poor spatial effect and narrow stage width. XY pairs have a SRA of  $\pm 90$  degrees and an angular distortion of roughly 6 degrees, narrowing the stereo image (Williams, 2004).

Using only intensity differences between the microphones, **Blumlein** stereo arrays (also referred to as the *stereosonic* system) produce a remarkably accurate image from the front of the array (Fig. 4). Because the microphones are pressure gradient and respond to signals on either side of the diaphragm, this array encodes ambience and reverberation information arriving at the rear of the array at the same level (but in reverse polarity) as the information from the front: as a result, Blumlein stereo will reveal the limitations of halls with poor acoustics.

In 1956, Holger Lauridsen expanded on Blumlein’s research, discovering that if a single cardioid microphone were positioned to capture the overall balance of the ensemble, a second bidirectional microphone could be used to provide all of the directional information, thus providing an array with excellent mono-compatibility (ideal for stereo radio broadcasts) and with a more evenly balanced frequency response than XY pairs, since the principal axis of the middle microphones is aimed at the center of the ensemble. The **middle-side** technique also provides post production options, since the *side* component (consisting largely of directional and ambient information) may be adjusted separately from the *mid* microphone (Fig. 5). For orchestral recordings, however, some producers have noted that this array lacks intimacy and provides poor depth perception. (Bartlett).

Beginning with Bell Labs' early experiments in stereo reproduction in the 1930's, **spaced pairs** (Fig. 6) have been a mainstay of orchestral recording: Eargle (2004) noted that "most of the American symphonic recordings made during the decades of the fifties and sixties were made basically in this manner" (p. 177). While spaced pairs lack the localization precision of coincident arrays, many engineers, producers, and performers prefer the "soft-focus" quality of these recordings as well as the improved low-frequency response typical of omnidirectional microphones (Ibid).

As a compromise between coincident and spaced arrangements, **near-coincident stereo arrays** (Fig. 7) are intended to closely match human hearing by separating the two elements by approximately the same distance as our ears (between 16 and 30 cm). The most common of these arrays are the O.R.T.F., N.O.S., and the D.I.N. techniques, each named for its European broadcast agency of origin. As a result of the slight separation between capsules, near-coincident arrays produce a sense of "air" or increased sense of space, largely due to timing differences above 1 kHz; while these differences may decrease mono-compatibility, any incurred phase differences tend to be less damaging than with widely spaced arrays.

### *Session Information & Instructions for Use*

There are several Pro Tools session on the included DVD, each intended to allow you to study the differences between common stereo recording techniques. In the music examples, a single source (solo piano, chamber ensemble) was recorded with multiple stereo arrays on separate tracks, allowing you to switch between these as the session is playing in real time. Since these arrays run concurrently, you may switch between tracks at any time to compare different arrays instantly (Fig. 8).

To switch quickly between tracks, you may wish to choose the *X-OR* latching solo mode. When this option is selected, you can switch instantly between tracks without having to mute one and then un-mute another, since any previously soloed track will be canceled.

Beyond the music examples, you will also find series of **360-degree walk-around recordings**, intended to demonstrate how material presented both in front of the array as well as to the sides and rear are represented in two-channel playback (Fig. 9).

Using both spoken word and 100 ms Gaussian white noise bursts every 10 degrees, these tracks illustrate how each stereo recording technique captures the stereophonic recording angle (SRA), image localization, and angular distortion. Since these recordings were performed in an anechoic chamber, the effects of room reflections and ambience, which might have otherwise impaired image localization, were negated. Each walk-around session includes both a long-form description of each position as well as an edited version. The edited versions of the tracks are *tick-based*, allowing you to adjust the playback speed of the narration around the array by changing the tempo of the session. The noise burst tracks are also tick-based, with an initial tempo setting of 60 beats per minute that produces one burst per second.

As you listen through, you may wish to make individual notes about each array type, including how different techniques influence your impressions of the ensemble and performance space. In previous studies, listeners were drawn to the spaciousness and accuracy of the near-coincident pairs, especially in contrast to the relatively narrow imaging of coincident arrays and the wide, “soft-focus” images from spaced arrays. When monitoring in headphones, you may be drawn to the extremely detailed three-dimensional imaging produced by the binaural recordings, though these do not translate well on conventional loudspeakers.

### *Further Study*

For additional information about stereo arrays, imaging, and stereophony, there are many excellent texts and websites available, several of which are included in the references section below. In particular, Michael Williams’ Multichannel Microphone Array Design is excellent:

[http://www.soundscot.com/MMAD\\_04/MAD/2%20Ch/2ch.htm](http://www.soundscot.com/MMAD_04/MAD/2%20Ch/2ch.htm)

Additionally, several pro audio manufacturers’ online educational materials are extremely valuable, including DPA, Røde, and Millennia.

<http://dpamicrophones.com/>

<http://www.rodeuniversity.com/>

<http://www.mil-media.com/>

## Credits and Thank you's

### Musicians:

Dr. Joseph Akins

The ALIAS Chamber Ensemble

Christopher Stenstrom, Director

Michael Samis

Melissa Rose

Lee Levine

The Siegel High School String Quartet (2008)

Lalo Davila and the MTSU Percussion Ensemble (2008)

### Graduate & Project Advisors

Dr. Bob Wood

Michael Fleming

John Hill

Dan Pfeifer

### Schermerhorn Symphony Center

Alan D. Valentine, President and CEO

Mark Blakeman, Vice President and General Manager

Ellen Hollis, Director of Event Services

Deborah Newmark, American Federation of Musicians, New York

Michael Wagener, for the gracious loan of the Neumann KU 100 ("Fritz")

Dr. Wesley Grantham, Dir. of Research, Vanderbilt Univ. Dept. of Hearing and Speech

John Gholston, Gear For Days

Michael Williams

Ron Streicher

Christine, Jack & Alex, for their ongoing support.

## References

- Bartlett, B. & Bartlett, J. (2007). *Recording Music On Location*. Oxford: Focal Press.
- Benjamin, E. (2006). An Experimental Verification of Localization in Two-Channel Stereo. *AES Convention Paper 6968*.
- Blumlein, A. (1958). British Patent Specification no. 394,325. Reprinted in *Journal of the AES*, 6(2). 91-98, 130.
- Shure Distribution UK. (n.d.) Critical Distance and Microphone Placement. *Shure Technical Library*. Retrieved on 19 October 2008 from [http://www.shure.co.uk/ProAudio/Products/us\\_pro\\_ea\\_critical](http://www.shure.co.uk/ProAudio/Products/us_pro_ea_critical)
- DPA Microphones (n.d.). Stereo Recording with DPA Microphones. *Microphone University*. Retrieved on 14 February 2007 from <http://dpamicrophones.com>
- Eargle, J. (2004). *The Microphone Book* (2<sup>nd</sup> ed.) Oxford: Focal Press.
- Eargle, J. (2005). *Handbook of Recording Engineering* (4<sup>th</sup> ed.) New York: Springer.
- Fleming, M. (2008). Classical Music Recording [class notes]. Murfreesboro, TN: Middle Tennessee State University. Spring, 2008
- Gerzon, M. (1975). Blumlein Stereo Microphone Technique. *Journal of the-AES*, 24(1). 36-38.
- Griesinger, D. (1975, March). Spaciousness and Localization in Listening Rooms – How To Make Coincident Recordings Sound As Spacious as Spaced Microphone Arrays. *Journal of the AES*, 34 (4). 255-268.
- Holman, T. (2001). *Sound for Film and Television* (2<sup>nd</sup> ed.) Oxford: Focal Press.
- Huggonet, C. & Walder, P. (1998). *Stereophonic Sound Recording: Theory and Practice*. Sussex: Wiley & Sons Ltd.
- Jeppesen, J. & Møller, H. Cues for Localization in the Horizontal Plane. *AES Convention Paper 6323*.
- Katz, B. (2007). *Mastering Audio: the art and the science* (2<sup>nd</sup> ed.) Oxford: Focal Press
- LeGrou, J. (2005). Large Ensemble Listening Test Tutorial. *Millennia Music and Media Systems*. Retrieved on 10 October 2008 from <http://www.mil-media.com/LargeEnsembleListeningTest.html>
- Lipshitz, S. (1986). Stereo Microphone Techniques – Are The Purists Wrong? *Journal of the AES*, 34(9). 716-744.

- Mellor, D. (2008). Microphone Polar Patterns and Stereo Configurations. *Audio Masterclass*. Retrieved 20 October 2008 from <http://www.record-producer.com/ebooks/store.cfm>
- Mickiewicz, W. (2004). Optimization of microphone setup for symphonic orchestra recordings during rehearsal. Berlin: *AES Convention Paper 6134*.
- Moylan, W. (2007). *Understanding and Crafting the Mix: The Art of Recording* (2<sup>nd</sup> ed.) Oxford: Focal Press.
- Nashville Symphony Orchestra information. (n.d.) *Schermerhorn Symphony Center*. Retrieved on 27 September 2008, from <http://www.nashvillesymphony.org/main.taf?p=17>
- Robjohns, H. (2006, May). Recording a String Section. *Sound on Sound*. Retrieved on 13 April 2008 from: <http://www.soundonsound.com/sos/may06/articles/recordingstrings.htm>
- Rumsey, F. & McCormick, T. (2005). *Sound and Recording: An Introduction* (5<sup>th</sup> ed.) Oxford: Focal Press.
- Streicher, R. & Everest, F. A. (2006). *The New Stereo Soundbook* (3<sup>rd</sup> ed.) Pasadena, CA: Audio Engineering Associates.
- Verna, P. (1 November 2000). The Changing Landscape of Orchestra Recording. *Mix Magazine Online*. Retrieved on 19 October 2008 from [http://mixonline.com/mag/audio\\_changing\\_landscape\\_orchestral/](http://mixonline.com/mag/audio_changing_landscape_orchestral/)
- Williams, M. (2005). Stereophonic dual microphone arrays. *Microphone Array Design*. Retrieved 12 March 2008 from [http://www.soundscot.com/MMAD\\_04/MAD/Ch\\_n\\_cov.htm](http://www.soundscot.com/MMAD_04/MAD/Ch_n_cov.htm)
- Williams, M. (1984). The Stereophonic Zoom: a practical approach to determine the characteristics of a spaced pair of microphones. *AES Convention Paper 2072*.
- Williams, M. (2004). *Microphone Arrays for Stereo and Multichannel Sound Recording, vol. 1*. Milan: Il Rostro.
- Wittek, H. & Theile, G. (2002). The Recording Angle – based on localization curves. *AES Convention Paper 5568*.
- Woram, J. & Kefauver, A. (1989). *The New Recording Studio Handbook*. New York: Elar Publishing.



## Illustrations

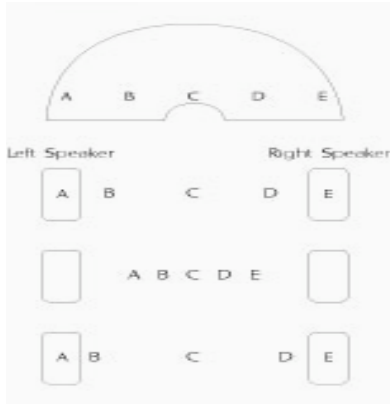

Fig. 1 Illustrations of angular distortion, showing irregularities between the original source and its perceived localization on playback. The middle example shows the image “clumping” in the center; the other examples show the “hole in the middle” effect (DPA)



Fig. 2 Neumann KU 100 dummy head system, used for binaural recordings (Neumann)

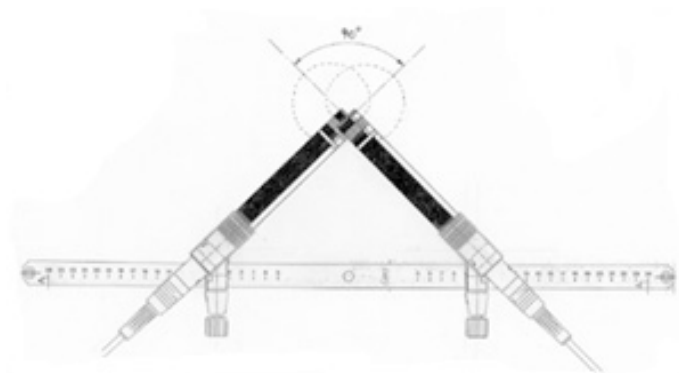

Fig. 3 Diagram of coincident cardioid microphones [XY pair] (DPA)

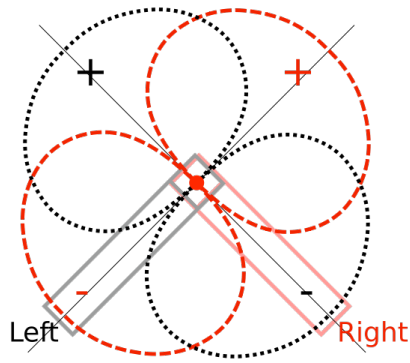

Fig. 4 Diagram of how the the Blumlein stereo technique works. Information from the rear quadrants appear on the opposite side of origin and in reverse polarity (Wikimedia)

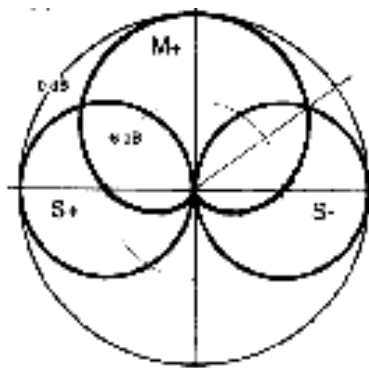

Fig. 5 Diagram of the middle-side technique. Although the *mid* element shown is a directional (cardioid) microphone, any polar pattern will work for this channel. (RawSound)

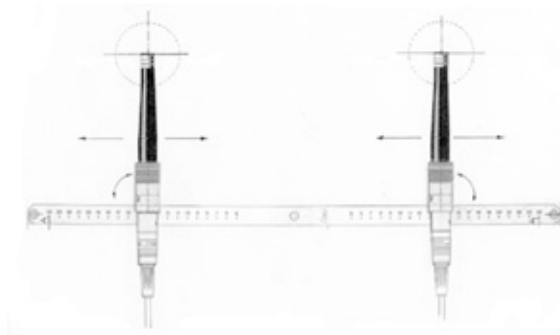

Fig. 6 Spaced omnidirectional microphones [AB pair]. (DPA)

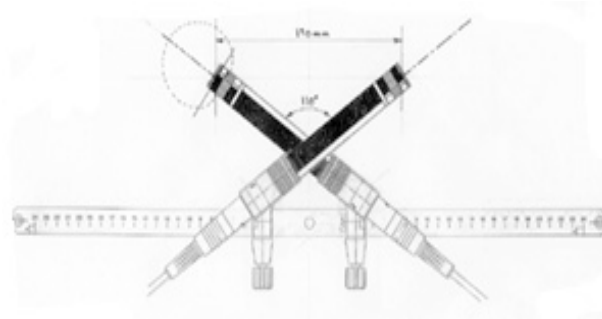

Fig. 7 Diagram of an ORTF near-coincident pair, with a included angle of  $110^\circ$  and a distance of 17 cm between capsules. (DPA)



Fig. 8 Image of Pro Tools session that includes multiple concurrent stereo arrays

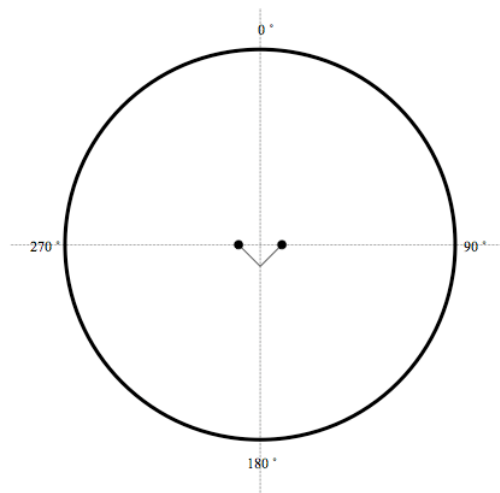

Fig. 9  $360^\circ$  walk-around of each stereo configuration. In the demo recordings, the recording radius was approximately 64 inches.